



**Mountaineering and
Climbing Equipment**

**UIAA
105**

'HARNESSES'

Foreword

This UIAA Standard is only published in the English language version, which is the master text. For any validations in translation, the UIAA Safety Commission should be contacted via the UIAA Office in Bern, Switzerland.

UIAA Standards are the only 'globally recognized' standards for mountaineering equipments. In order to prevent multiplicity, the UIAA collaborates with its partner in standardization CEN; and bases UIAA standard 105 on the European Standard EN 12277:2015. The EN Standards in turn are based on the original UIAA Standards, the first of their kind in the world. Additionally the UIAA publishes pictorials for each of the standards in a user-friendly way. This UIAA Standard 105 also has additional requirements over and above those in EN 12277:2015.

Owing to copyright restrictions, this UIAA Standard does not state the full requirements of EN 12277:2015 to which it refers. Hence it is necessary to obtain a copy of EN 12277:2015. The procedure for purchasing the EN Standards is included at the end of the text of this standard. The UIAA Standards are reviewed at intervals to see whether they meet the latest technical requirements and revised if necessary.

The UIAA invites manufacturers of mountaineering and climbing equipment worldwide to become members of the UIAA Safety Commission as Safety Label Holders. Members can participate in discussions on standard requirements, test methods and revisions thereof (see the "General Regulations for the UIAA Safety Label").

A complete list of UIAA Standards for mountaineering and climbing equipment can be found on the UIAA website.

The UIAA Safety Commission, which is responsible for the UIAA Standards, expects that the corresponding EN Standard will be updated to include the additional requirements of the UIAA Standard.

© 2013 UIAA

Copyright is secured for the present standard work including all its parts. Any use beyond the limit of the copyright act is forbidden by law.

This concerns especially copying, microfilming and feeding and processing in electronic data systems.

VERSION	UIAA 105_3
LAST UPDATED	30 May 2014
COMPLIANCE DATE	One year period since official publication

www.theuiaa.org

UIAA, Monbijoustrasse 61, Postfach, CH - 3000 Bern 23, Switzerland
t: +41 31 370 18 28 e: office@theuiaa.org



THE INTERNATIONAL MOUNTAINEERING AND CLIMBING FEDERATION
UNION INTERNATIONALE DES ASSOCIATIONS D'ALPINISME

Office: Monbijoustrasse 61 • Postfach
CH-3000 Bern 23 • Switzerland
tel: +41 (0)31 370 1828 • fax: +41 (0)31 370 1838
e-mail: office@theuiaa.org

SAFETY

1. General Remarks on the UIAA Trademark and UIAA Label

- 1.1. The UIAA Trademark (see section 5.1.) is copyright protected internationally. The UIAA Label is only given to items of mountaineering and climbing equipment upon approval of prospective label holder's application from the UIAA.
- 1.2. The procedure to be followed by a manufacturer, when applying for a UIAA Label, is laid down in the "General Regulations for the UIAA Safety Label Certification".

2. Requirements for Harnesses

- 2.1. The UIAA Label can only be granted for harnesses which meet all the requirements of EN 12277:2015, with the following exception:
 - 2.1.1. No EN number required.
- 2.2. For the award of the UIAA Label, the following additional safety requirements shall be met:
 - 2.2.1. Safety Requirements
If there is a textile means of attachment, whose strength is dependent on the integrity of the stitching, and then at least 50 % of the visible area of the stitching shall contrast with the background colour.
 - 2.2.2. Test Method
Check by visual examination that the requirements according to 2.2.1 are met.
- 2.3. Belt test requirement

The test method described in 5.2.6.4 and figure 4 of EN 12277:2015 are replaced by:

Affix the belt of the harness to the cylinder as shown in Figure 2 and attach the attachment point of the harness with a pin of diameter $(12 \pm 0,1)$ mm to the test machine. Apply a force increasing gradually to (300 ± 10) N over a period of (30 ± 10) s. Control the angle of the belt to be $(55 \pm 5)^\circ$ by adjusting the length of the belt. Position the belt on the cylinder so that the attachment point of the harness and the fixation element of the cylinder are aligned within the direction of the applied force. If the belt has an adjusting device for the length, make a mark at the outer edge of any load bearing buckle or adjusting device.

Apply a force increasing gradually to $(10^{+0,1}_0)$ kN over a period of $(2 \pm 0,25)$ min. Hold this force for $(1 \pm 0,25)$ min and release the tension completely over a period of 60 seconds. Reapply the force immediately and increase the force gradually to $(10^{+0,1}_0)$ kN over a period of $(3 \pm 0,25)$ min. Hold this force for $(3 \pm 0,25)$ min before releasing the force completely. After releasing the tension completely, if relevant, make a mark at the outer edges of any load bearing buckle or adjusting device. Undo the load bearing buckle or adjusting device and measure the distance between the two marks.

Key

SAFETY

- a) The load bearing buckle or adjusting device shall not touch the cylinder
- 1 Fixation element of the cylinder
 - 2 Harness attachment point

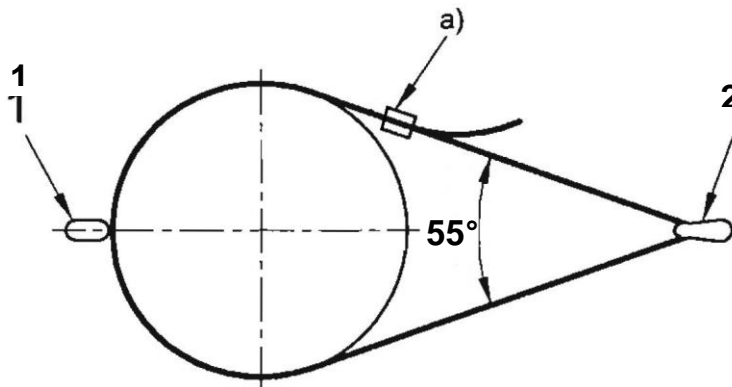

3. Fig. 4

4.

Diameter of the cylinder: (250 ± 10) mm. Diameter of (160 ± 10) mm if the load bearing buckle or adjusting device touches the cylinder of 250 mm.

5. Demonstrating that the Requirements are met

- 5.1. The requirements of section 2.1. shall be satisfied by a test report from a UIAA-approved test laboratory.
- 5.2. The requirements of section 2.2 shall be satisfied by the manufacturer certifying on the Safety Label Test Template Form that the product meets this particular requirement.

6. Information to be supplied

- 6.1. The information to be supplied (in accordance with EN 12277:2015) shall be given in English, or at least in the language of the country in which the product is sold.



THE INTERNATIONAL MOUNTAINEERING AND CLIMBING FEDERATION
UNION INTERNATIONALE DES ASSOCIATIONS D'ALPINISME

Office: Monbijoustrasse 61 • Postfach
CH-3000 Bern 23 • Switzerland
tel: +41 (0)31 370 1828 • fax: +41 (0)31 370 1838
e-mail: office@theuiaa.org

SAFETY

7. Attachment of the UIAA Label

- 7.1. For any model of mountaineering equipment, which has been awarded the UIAA Label, the UIAA recommends that the UIAA Trademark (see below) or the four letters "UIAA" be marked clearly and indelibly on each item sold in accordance with the branding guidelines specified in the "General regulations for UIAA Safety Label".



UIAA

- 7.2. In addition, the UIAA Trademark or the four letters "UIAA" may be included in the instructions for use and/or on a swing ticket as well as in catalogues and other publications of the manufacturer. In the last case, the illustration and/or the text must clearly apply only to the equipment which has been awarded the UIAA Label.

Last Updated	Remarks
<i>May 2014</i>	<u>Inclusion of section 2.3. Belt test requirement</u>
<i>March 8, 2013</i>	<u>Corrections of last EN norm + in point 3</u>
<i>December 2016</i>	<u>All mentioned EN 12277:2007 have been replaced with EN 12277:2015</u>



THE INTERNATIONAL MOUNTAINEERING AND CLIMBING FEDERATION
UNION INTERNATIONALE DES ASSOCIATIONS D'ALPINISME

Office: Monbijoustrasse 61 • Postfach
CH-3000 Bern 23 • Switzerland
tel: +41 (0)31 370 1828 • fax: +41 (0)31 370 1838
e-mail: office@theuiaa.org

SAFETY

Copies of the EN Standards can be purchased from the following:

Great Britain British Standards Institution (BSI), Tel: +44 20 8996 9001
Order by Fax: +44 20 8996 7001 (with credit card details)
by post: BSI Customer Services c/o Cash Office,
PO Box 16206, London W4 4ZL (cash with order)

France: Association Francaise de Normalisation (AFNOR),
Serv. "Qualite de la Vie" (SQV), Tour Europe,
F-92049 Paris La Défense CEDEX
TEL: + 33 142 91 55 33 FAX: + 33 142 91 56 56

Germany: Beuth-Verlag GmbH, Burggrafenstrasse 4-10,
D-10787 Berlin
TEL: +49 30 2601 2260 FAX: +49 30 2601 1260

Italy: Ente Nazionale Italiano di Unificazione (UNI),
Via Battistotti Sassi 11/b, I-20133 Milano
TEL: +39 270 0241 FAX: +39 270 106 106

Spain: Asociación Española de Normalización y Certificación
(AENOR), Genova 6, E-28004 Madrid
TEL: + 34 14 32 60 00 FAX: + 34 13 10 45 96
